

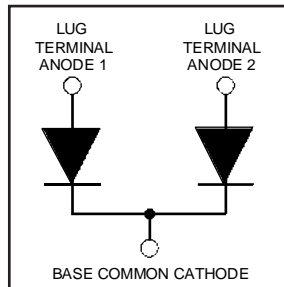
# HFA160NJ40C

HEXFRED™

Ultrafast, Soft Recovery Diode

## Features

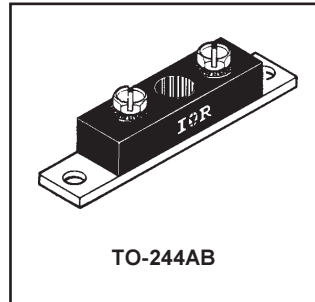
- Reduced RFI and EMI
- Reduced Snubbing
- Extensive Characterization of Recovery Parameters



$V_R = 400V$
$V_F(\text{typ.})^{\textcircled{3}} = 1V$
$I_{F(AV)} = 160A$
$Q_{rr}(\text{typ.}) = 420nC$
$I_{RRM}(\text{typ.}) = 9.3A$
$t_{rr}(\text{typ.}) = 36ns$
$di_{(rec)}/dt(\text{typ.})^{\textcircled{3}} = 260A/\mu s$

## Description

HEXFRED™ diodes are optimized to reduce losses and EMI/RFI in high frequency power conditioning systems. An extensive characterization of the recovery behavior for different values of current, temperature and di/dt simplifies the calculations of losses in the operating conditions. The softness of the recovery eliminates the need for a snubber in most applications. These devices are ideally suited for power converters, motors drives and other applications where switching losses are significant portion of the total losses.



## Absolute Maximum Ratings (per Leg)

	Parameter	Max.	Units
$V_R$	Cathode-to-Anode Voltage	400	V
$I_F @ T_C = 25^\circ C$	Continuous Forward Current	170	A
$I_F @ T_C = 100^\circ C$	Continuous Forward Current	84	
$I_{FSM}$	Single Pulse Forward Current <sup>①</sup>	600	
$E_{AS}$	Non-Repetitive Avalanche Energy <sup>②</sup>	1.4	mJ
$P_D @ T_C = 25^\circ C$	Maximum Power Dissipation	310	W
$P_D @ T_C = 100^\circ C$	Maximum Power Dissipation	125	
$T_J$ $T_{STG}$	Operating Junction and Storage Temperature Range	-55 to +150	C

## Thermal - Mechanical Characteristics

	Parameter	Min.	Typ.	Max.	Units
$R_{thJC}$	Junction-to-Case, Single Leg Conducting	—	—	0.48	°C/W K/W
	Junction-to-Case, Both Legs Conducting	—	—	0.24	
$R_{thCS}$	Case-to-Sink, Flat, Greased Surface	—	0.10	—	
$Wt$	Weight	—	79 (2.8)	—	g (oz)
	Mounting Torque <sup>④</sup>	30 (3.4)	—	40 (4.6)	lbf•in (N•m)
	Mounting Torque Center Hole	12 (1.4)	—	18 (2.1)	
	Terminal Torque	30 (3.4)	—	40 (4.6)	
	Vertical Pull	—	—	80	lbf•in
2 inch Lever Pull	—	—	35		

**Note:** <sup>①</sup> Limited by junction temperature  
<sup>②</sup> L = 100μH, duty cycle limited by max  $T_J$   
<sup>③</sup> 125°C

<sup>④</sup> Mounting surface must be smooth, flat, free of burrs or other protrusions. Apply a thin even film of thermal grease to mounting surface. Gradually tighten each mounting bolt in 5-10 lbf•in steps until desired or maximum torque limits are reached. Module

# HFA160NJ40C

PD-2.467 rev. B 02/99

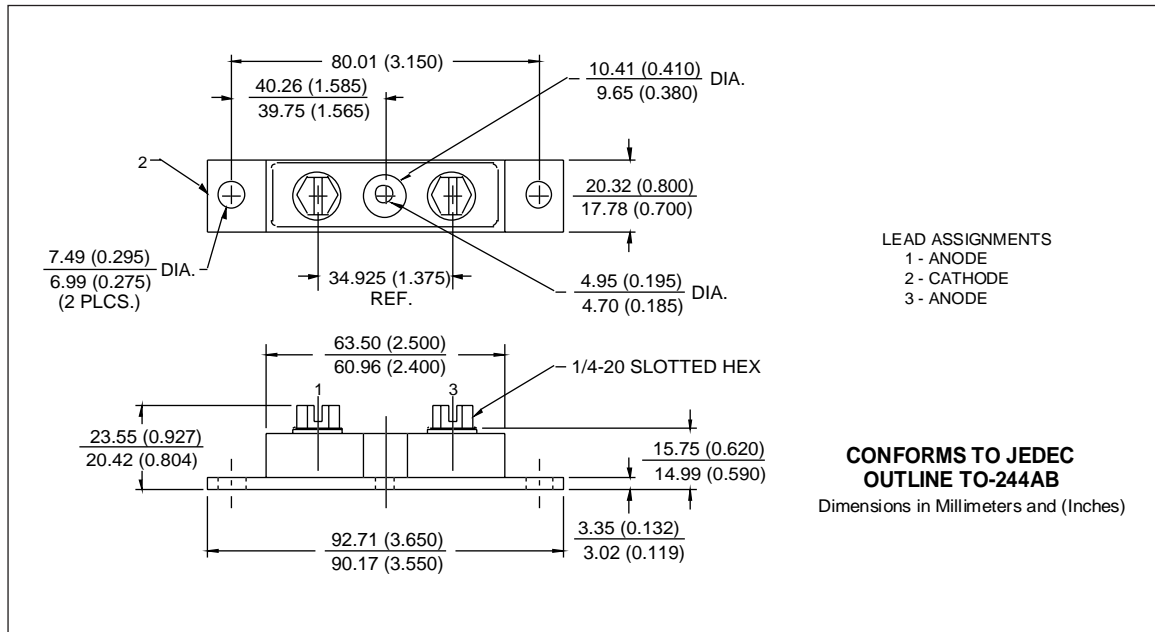
International  
**IOR** Rectifier

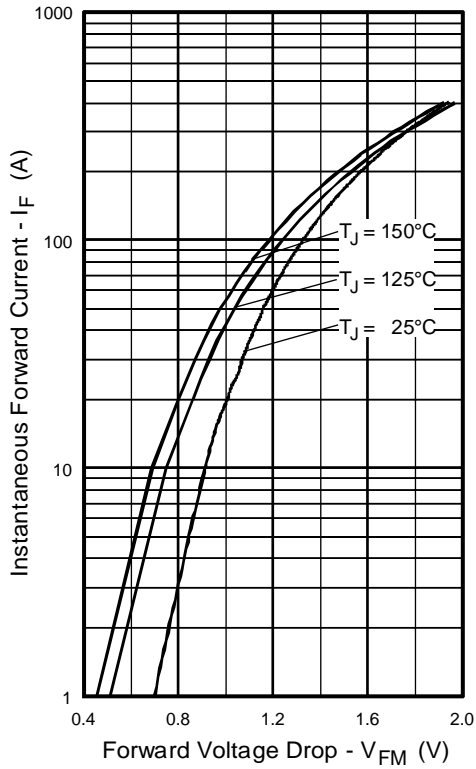
## Electrical Characteristics (per Leg) @ T<sub>J</sub> = 25°C (unless otherwise specified)

Parameter	Min.	Typ.	Max.	Units	Test Conditions	
V <sub>BR</sub>	400	—	—	V	I <sub>R</sub> = 100μA	
V <sub>FM</sub>	—	1.1	1.3	V	I <sub>F</sub> = 80A I <sub>F</sub> = 160A I <sub>F</sub> = 80A, T <sub>J</sub> = 125°C	
	—	1.3	1.5			See Fig. 1
	—	1.0	1.2			
I <sub>RM</sub>	—	1.0	6.0	μA	V <sub>R</sub> = V <sub>R</sub> Rated	
	—	1.5	8.0	mA	T <sub>J</sub> = 125°C, V <sub>R</sub> = 320V	
C <sub>T</sub>	—	180	260	pF	V <sub>R</sub> = 200V	
L <sub>S</sub>	—	7.0	—	nH	From top of terminal hole to mounting plane	

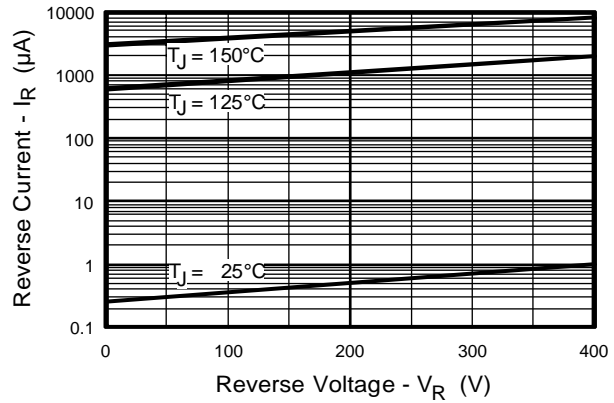
## Dynamic Recovery Characteristics (per Leg) @ T<sub>J</sub> = 25°C (unless otherwise specified)

Parameter	Min.	Typ.	Max.	Units	Test Conditions	
t <sub>rr</sub>	—	36	—	ns	I <sub>F</sub> = 1.0A, di <sub>f</sub> /dt = 200A/μs, V <sub>R</sub> = 30V T <sub>J</sub> = 25°C T <sub>J</sub> = 125°C	
t <sub>rr1</sub>	—	90	140			See Fig. 5
t <sub>rr2</sub>	—	160	240			
I <sub>RRM1</sub>	—	9.3	17	A	T <sub>J</sub> = 25°C T <sub>J</sub> = 125°C	
I <sub>RRM2</sub>	—	15	30			
Q <sub>rr1</sub>	—	420	1100	nC	T <sub>J</sub> = 25°C T <sub>J</sub> = 125°C	
Q <sub>rr2</sub>	—	1200	3200			
di <sub>(rec)M</sub> /dt1	—	360	—	A/μs	T <sub>J</sub> = 25°C T <sub>J</sub> = 125°C	
di <sub>(rec)M</sub> /dt2	—	260	—			

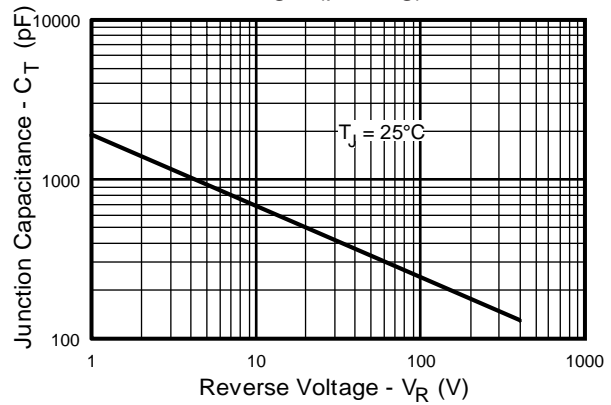




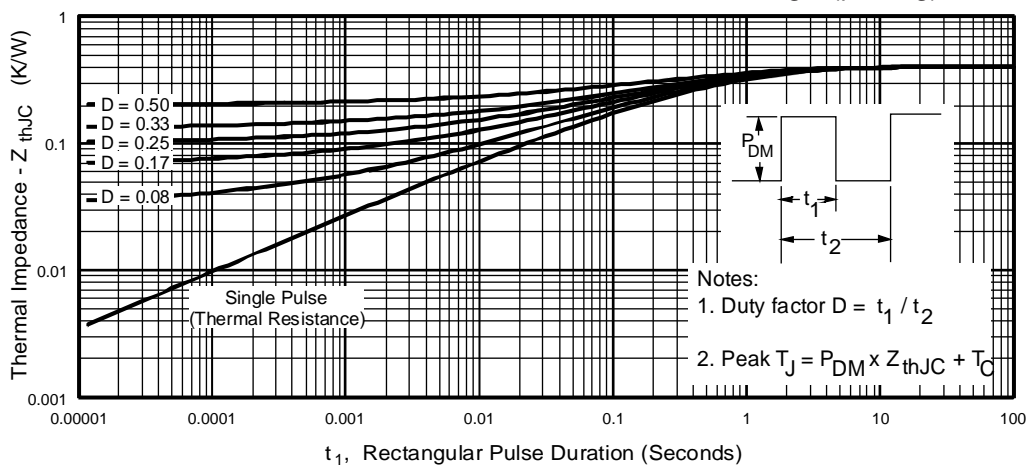
**Fig. 1** - Maximum Forward Voltage Drop vs. Instantaneous Forward Current, (per Leg)



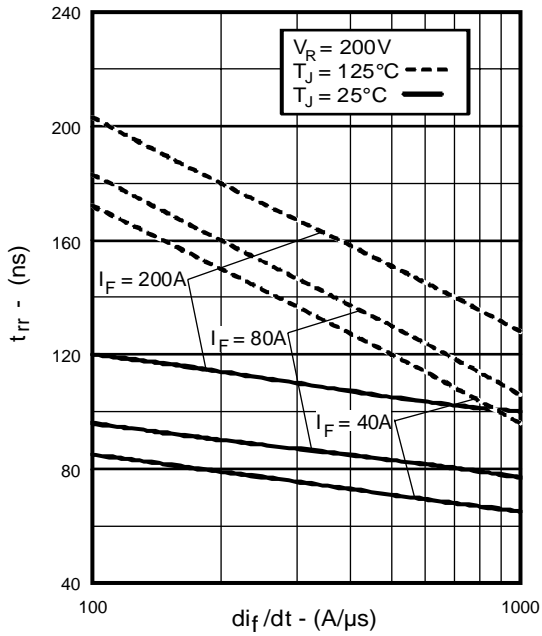
**Fig. 2** - Typical Reverse Current vs. Reverse Voltage, (per Leg)



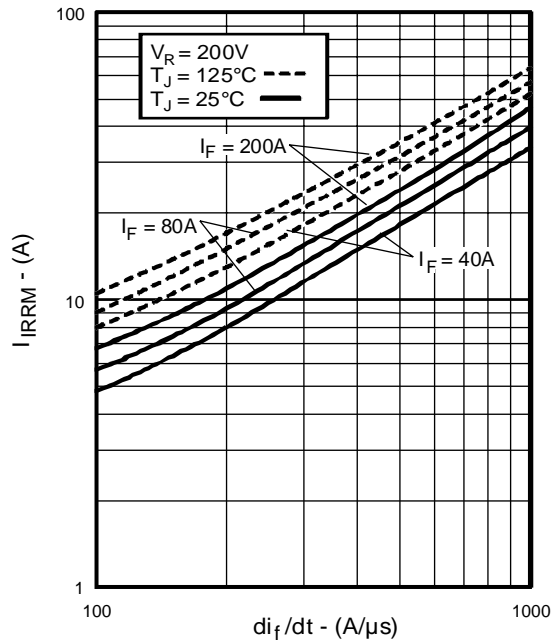
**Fig. 3** - Typical Junction Capacitance vs. Reverse Voltage, (per Leg)



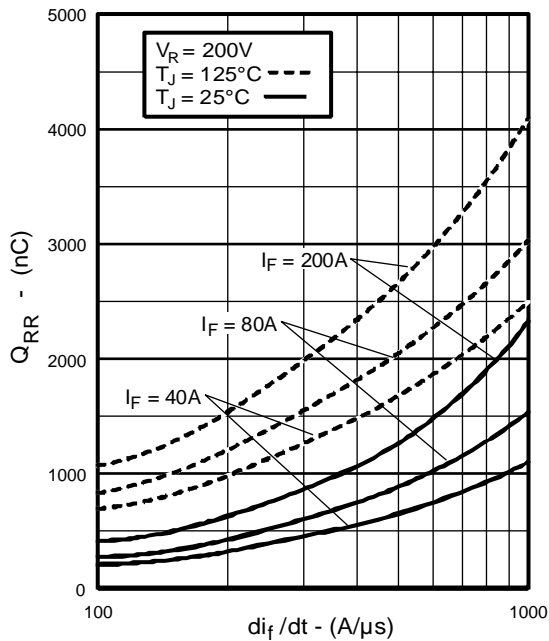
**Fig. 4** - Maximum Thermal Impedance  $Z_{thJC}$  Characteristics, (per Leg)



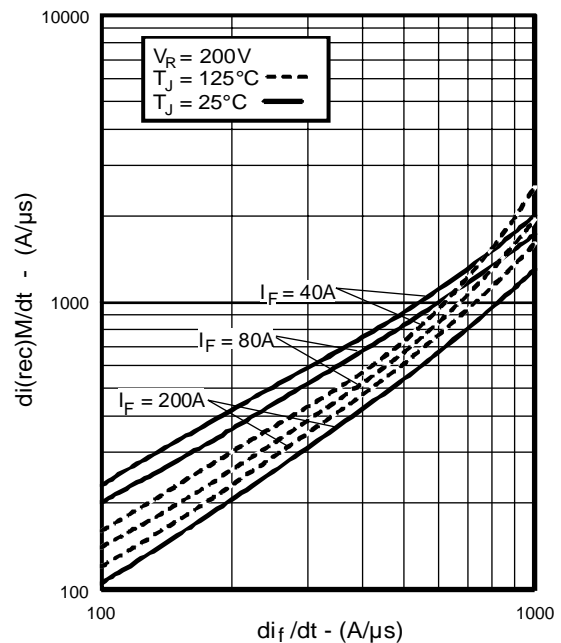
**Fig. 5** - Typical Reverse Recovery vs.  $di_f/dt$ , (per Leg)



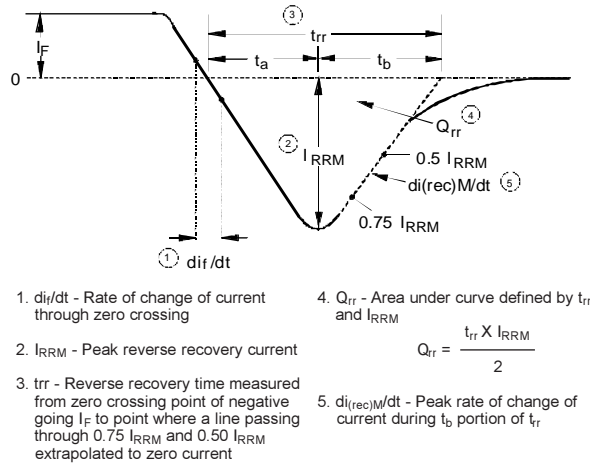
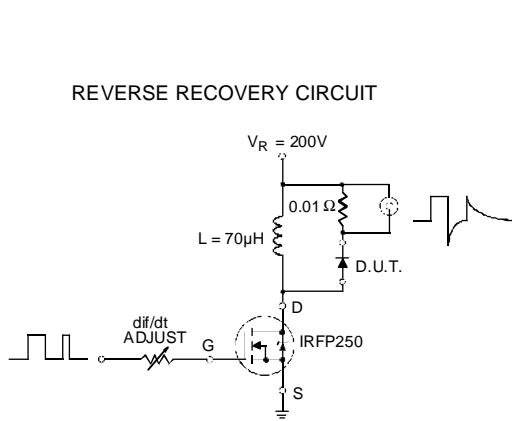
**Fig. 6** - Typical Recovery Current vs.  $di_f/dt$ , (per Leg)



**Fig. 7** - Typical Stored Charge vs.  $di_f/dt$ , (per Leg)

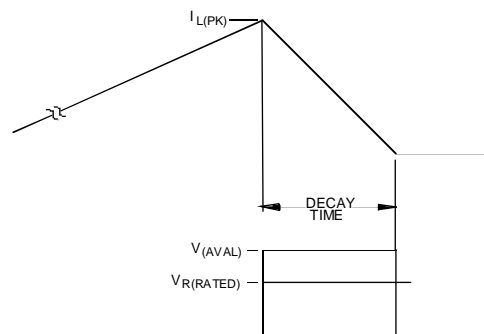
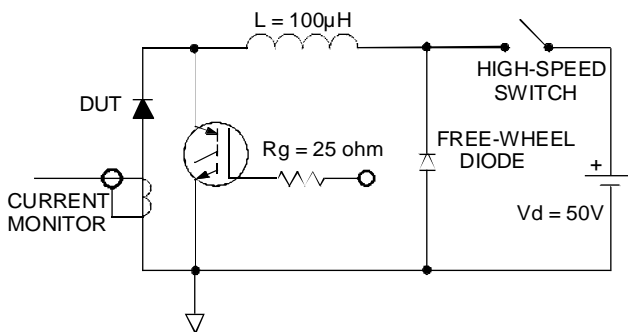


**Fig. 8** - Typical  $di_{(rec)M}/dt$  vs.  $di_f/dt$ , (per Leg)



**Fig. 9** - Reverse Recovery Parameter Test Circuit

**Fig. 10** - Reverse Recovery Waveform and Definitions



**Fig. 11** - Avalanche Test Circuit and Waveforms